

# FLEX

MULTI-STRETCH

The FLEX Multi-Stretch is equipped with a robust and weatherproof rubber massage roller and numerous fixed stretching anchor points that help people improve their flexibility and overall physical well-being. The FLEX is a complete warmup, cool-down, and recovery exercise system.

## Real Fitness Equipment for Real Results

The FLEX promotes optimal tissue health and resilience. Featuring essential upper and lower body static and dynamic stretches, the Flex delivers them to the outside world in a tamperproof, durable, and weatherproof package.

Designed for any fitness level or ability and is compact, cost-effective, and completely safe.



 **TAMPERPROOF.**  **WEATHERPROOF.**  **SAFE.**

### CHIROPRACTIC CERTIFIED

Designed in collaboration with the expertise of a certified chiropractic physician to deliver biomechanically correct stretches to optimize performance through adequate training and recovery.

The FLEX fits almost any user ages 13+ with no adjustment needed.

### 18+ DIFFERENT STRETCHES

The FLEX features over 18 different stretches that target major muscle groups.

Combining self-myofascial release techniques with dynamic and static stretching options, the FLEX promotes optimal tissue health and resilience.

### INTEGRATED RUBBER ROLLER

The integrated rubber roller on the FLEX takes your outdoor warmup and recovery to new levels by providing deep tissue release to the body's most used muscles.

Fixed to the unit and constructed from super durable rubber, the massage roller is low maintenance, completely weatherproof, and has no pinch points or entrapment areas.

# The FLEX Multi-Stretch is built to maximize indoor or outdoor exercise areas, with over 18 stretches available:

## UPPER BODY STRETCHES

- Standing Stretch
- Shoulder Stretch
- Side Bending Stretch
- Chest Stretch
- Bicep Stretch
- Upper Trap Stretch

## LOWER BODY STRETCHES

- Hip Swings
- Standing Hip Flexor/Calf Stretch
- Standing Hip Opener
- Figure Four Glute Stretch
- Inner Thigh Stretch
- Deep Calf Stretch

## RECOVERY STRETCHES

- Quadriceps Release
- Glute Release
- Hamstrings Release
- Lateral Hip Release
- Calf Release
- Mid-Back Release



## TECHNICAL SPECIFICATIONS



**Width:** 38" / 97 cm

**Length:** 36" / 92 cm

**Height:** 56" / 143 cm

**Weight:** 155 lbs / 71 kg

**Use Zone:** 10'9" x 9'2"



**Ages:** 13+ Years

**Accessibility:** It is the manufacturers' opinion that the above fitness areas conform to the A.D.A accessibility standard assuming an accessible protective surfacing is provided, as indicated, or within the entire use zone.



**Anchoring Requirements:** 4 x concrete anchors with rated "pull out" or "tension" strength of 3400lbs or greater. Anchors must be secured into structural concrete.

**Frame & Finish:** Constructed of 3/16" and 1/4" heavy duty steel that is zinc primed and polyester powder coated with UV stabilized color pigment. All fasteners are tamperproof stainless steel carriage bolts with the locking nuts confined behind an inaccessible steel plate.

The rubber roller is constructed from a super durable urethane rubber with a 60 durometer.

**Standard Color:** RAL 5001 Green Blue. Custom colors available for an extra charge.

**Shipping Weight:** 210 lbs 96 kg

**Shipping Dimensions:** 40" wide x 40" long x 62" high / 102 cm wide x 102 cm long x 158 cm high

**Number of Simultaneous Users:** 2



## CAD DRAWING

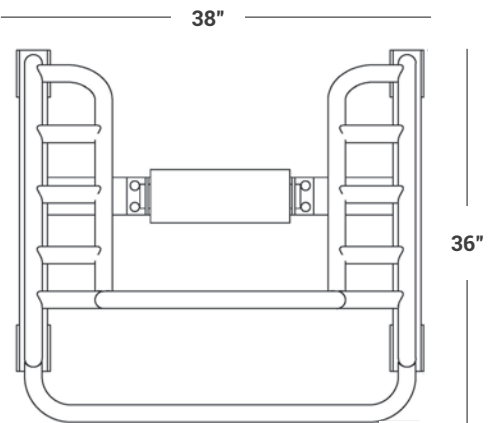

**FLEX**  
MULTI-STRETCH